

Main Housing Assemble

Number	Name
1	Control Panel
2	Diode window
3	Housing
4	Window frame
5	Pendulum
6	Battery cover
7	Locking base

RH-9502
Cross Line Laser Level 50M

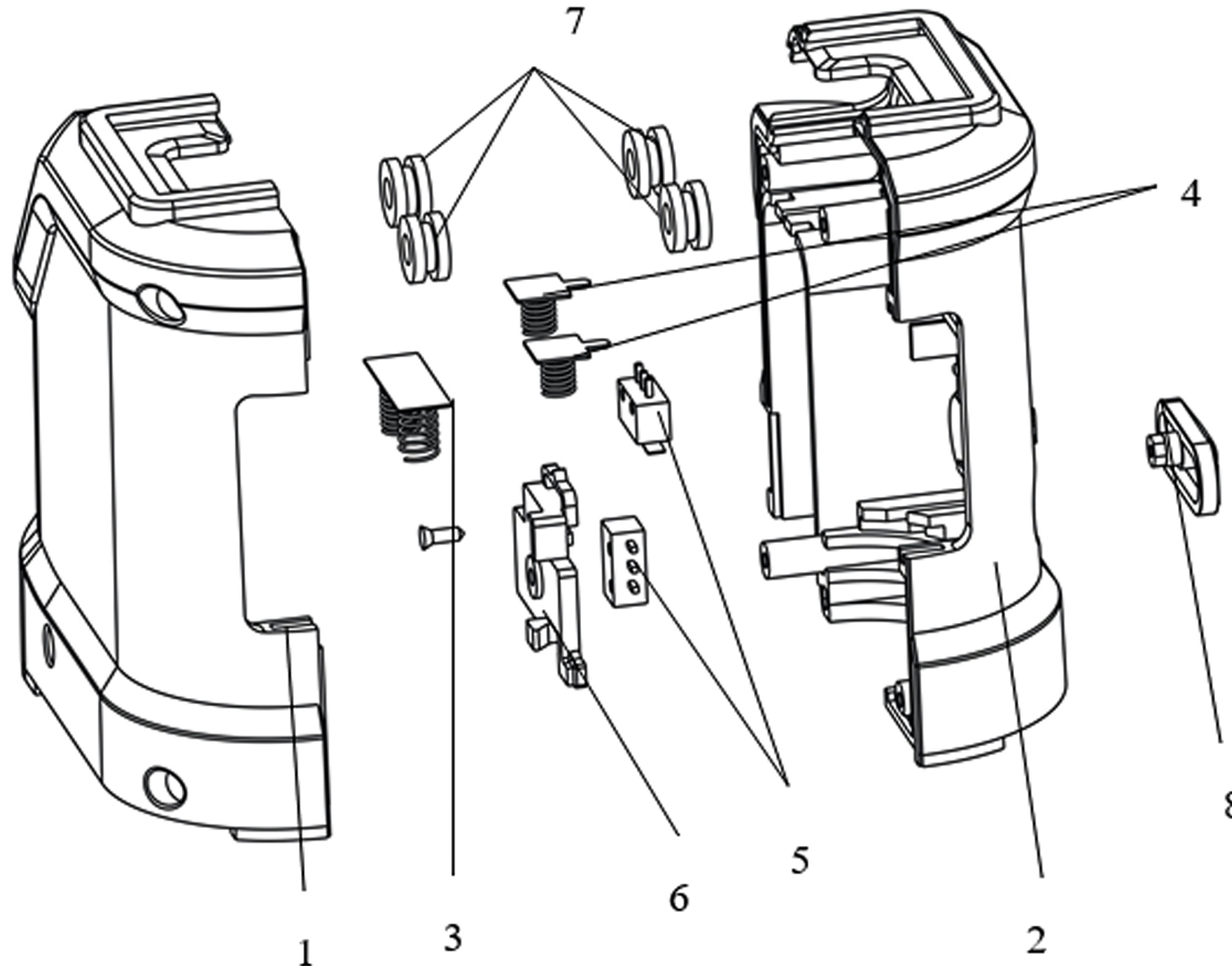

Housing

Number	Name
1	Left housing
2	Right housing
3	Battery reed B
4	Battery reed A
5	Limit switch
6	Conduction plate
7	Rubber ring
8	Pushing Button
9	Screw ST2.2x6
10	Micro Speaker

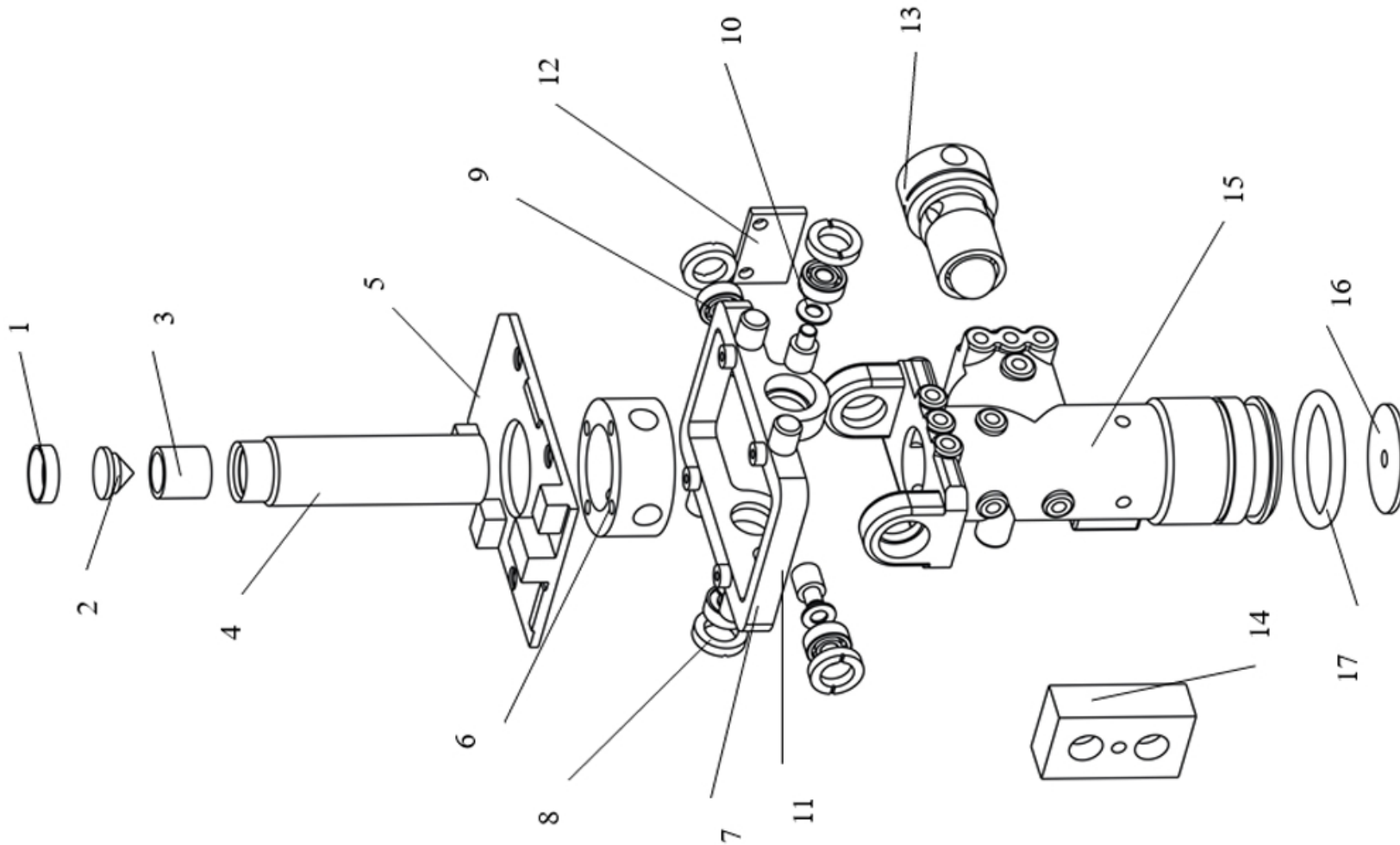

Pendulum Structure

Number	Name
1	Pipe shroud
2	Core glass
3	Glass tube
4	Diode
5	Main pcb
6	Inner bearing
7	Outer bearing
8	Locking bearing
9	Bearing 693
10	Bearing pipe
11	Roller pin
12	Conduction board
13	V diode
14	Main counterweight
15	Pendulum
16	Damping fin
17	O ring 18x2.65 (electric conduction)
18	Screw M3x8
19	Screw M3x6
20	Screw M3x8
21	Screw ST2.2x6
22	Screw M3x6

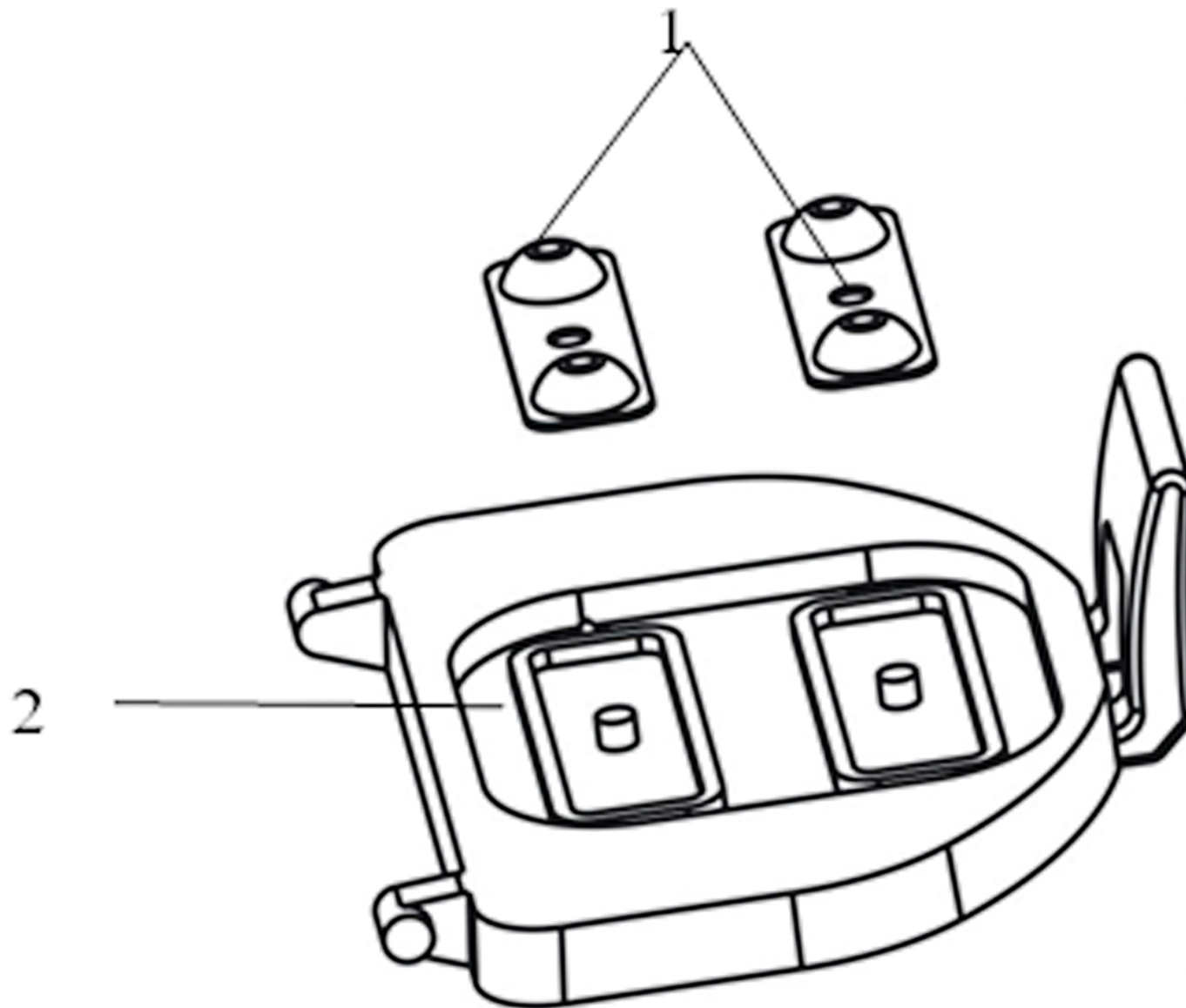

Battery Cover Assemble

Number	Name
1	Battery reed C
2	Battery cover

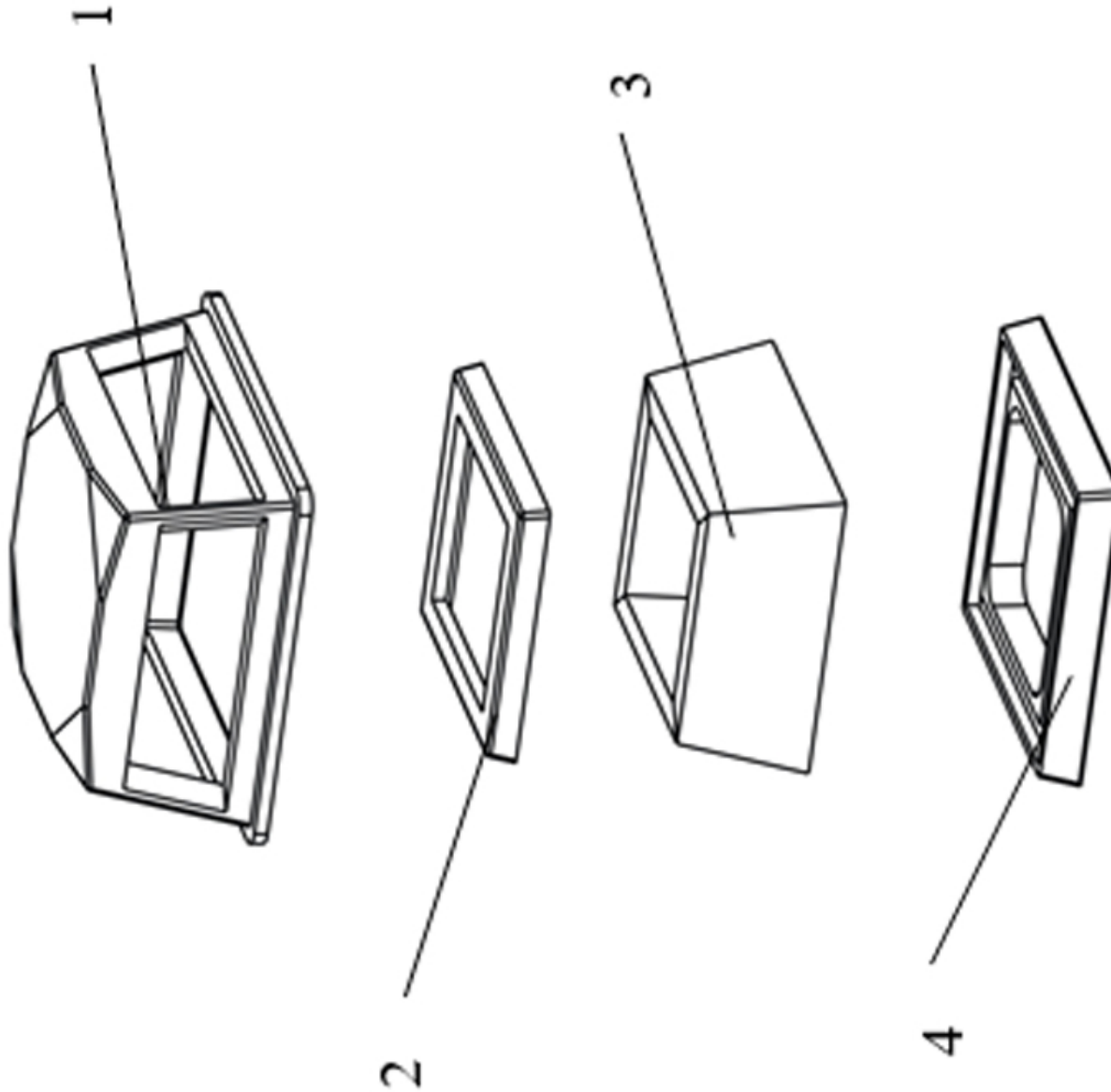

Window Assemble

Number	Name
1	Window frame
2	Rubber blanket 1
3	Glass
4	Rubber blanket 2

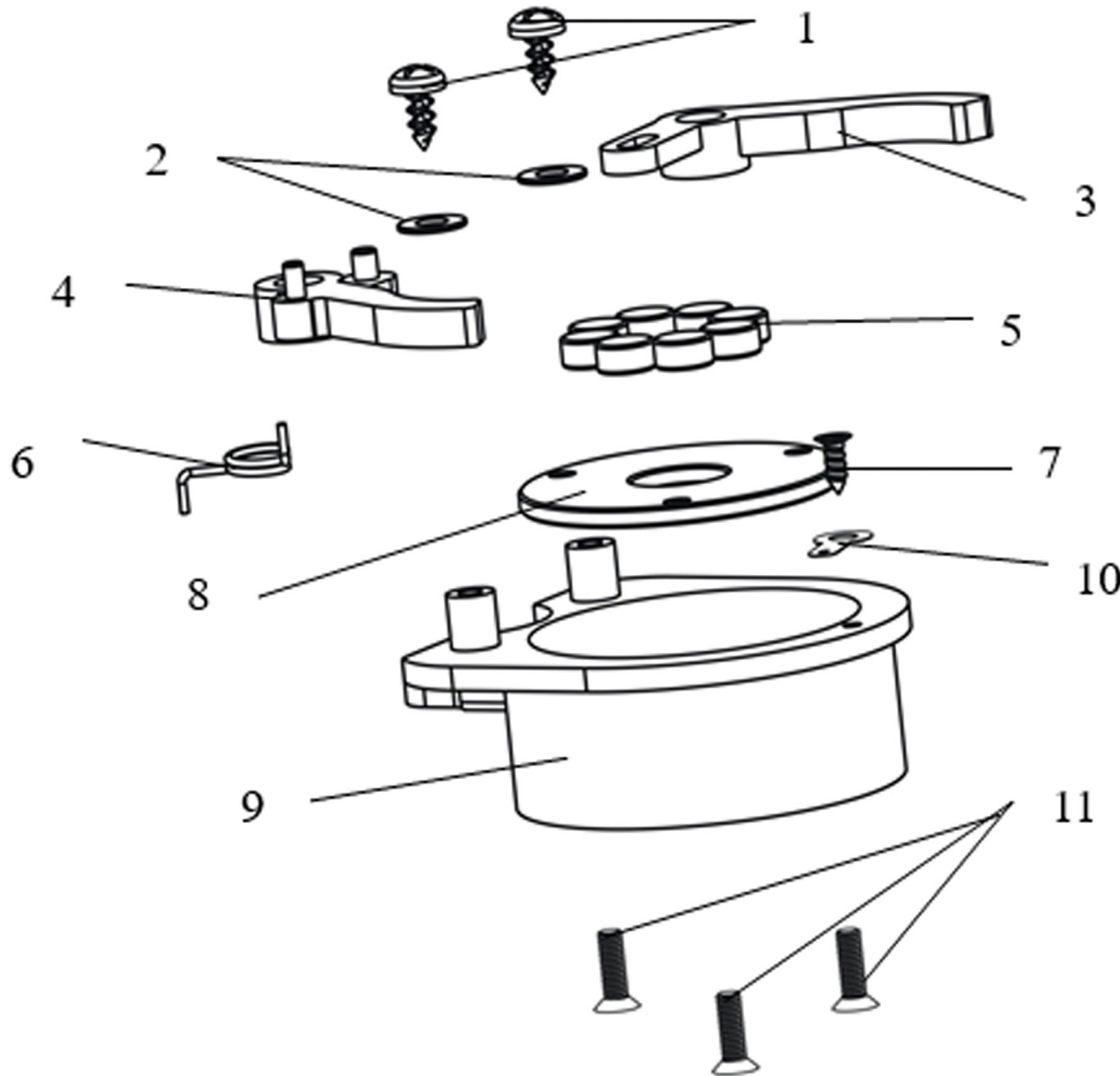

Locking System

Number	Name
1	Screw ST1.9x9.5
2	Flat washer 3
3	Left locking clamp
4	Right locking clamp
5	Magnetic plate
6	Spring
7	Screw ST2.2x6
8	Magnetic base
9	Locking base
10	JCT-A 8(W)x111(L)
11	Screw M2.5x6

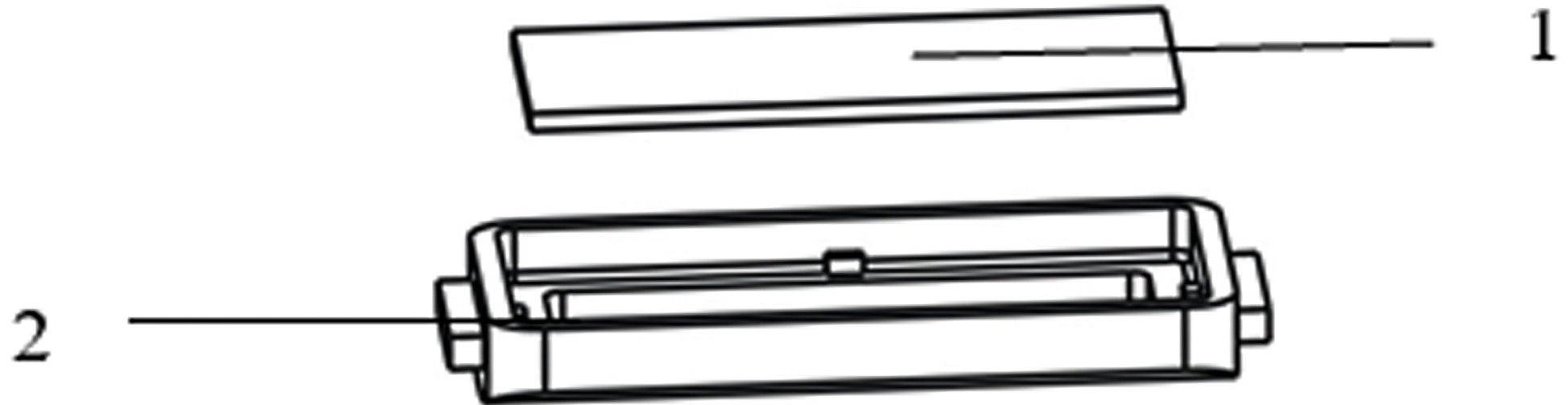

Window Frame

Number	Name
1	window glass
2	Window frame

MEASURING TOOLS

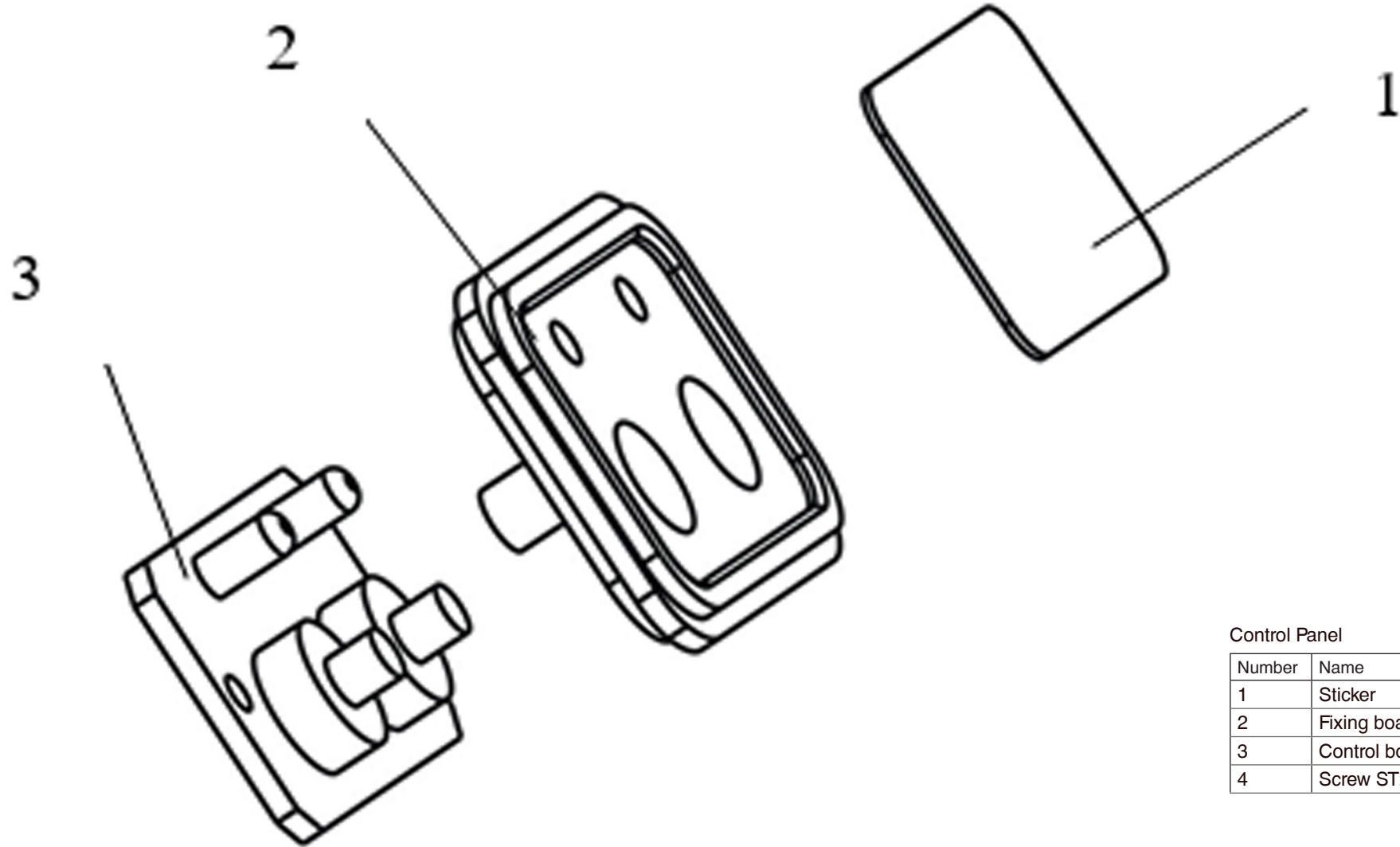

Control Panel

Number	Name
1	Sticker
2	Fixing board
3	Control board
4	Screw ST2.2x6