

Ronix®

Premium Quality

SOCKET FUSION

RH-4404

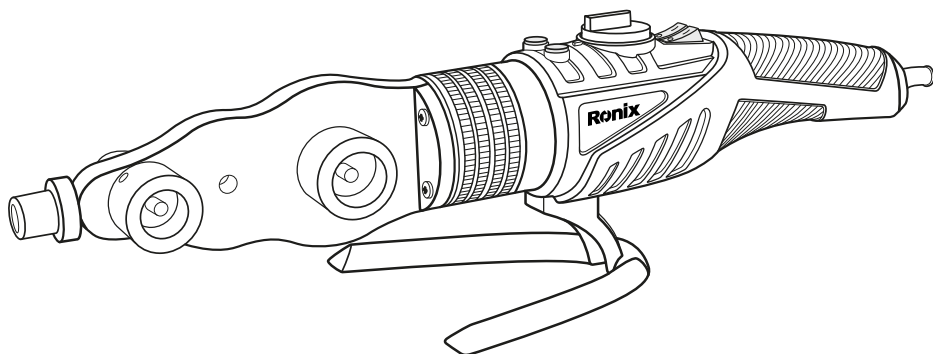

www.ronixtools.com

12
MONTHS
GUARANTY

FREE
DELIVERY

BANK
SPARE PARTS

CALL
CENTER
02161904

TECHNOLOGICAL DATA

Model	RH-4404
Power	2000W
Voltage	220V/240V
Frequency	50-60Hz
Type	B-2
Temperature rising time	2min
Thermostat	16 Amp
Temperature	50°~300 °c

PARTS LIST

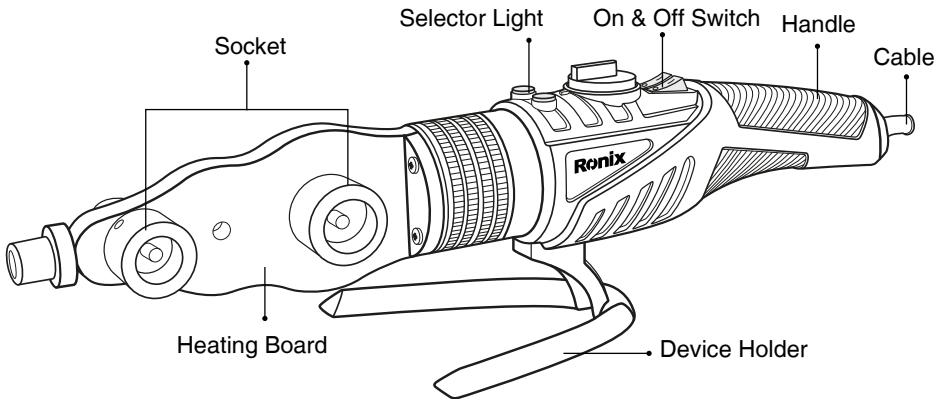

SAFETY INSTRUCTION

■ GENERAL POWER TOOLS SAFETY WARNINGS

⚠ WARNING!

When using electric tools, basic safety precautions, including the following, should always be followed to reduce the risk of fire, electric

shock and personal injury. Read all these instructions before operating this product and save these instructions.

■ ELECTRICAL SAFETY

If the supply cord is damaged, it must be replaced by the manufacturer, its service agent or similarly qualified persons in order to avoid a hazard.

■ PERSONAL SAFETY

This appliance can be used by children aged from 8 years and above and persons with reduced physical, sensory or mental capabilities or lack of experience and knowledge if they have been given supervision or instruction concerning use of the appliance in a safe way and understand the hazards involved. Children shall not play with the appliance.

Cleaning and user maintenance shall not be made by children without supervision.

SAFETY WARNINGS FOR SOCKET FUSION

This product adopt two plug of European standard, please do not change the plug, and must use the socket with the earth wire. In use process, hand and combustibles can not touch electric melting part to avoid accident.

Laypeople do not open the goods in order to avoid get an electric shock and breaks the safe function of the instrument. If there has malfunctions must be maintained by profession personnel or factory please do not tear down optionally.

INSTRUCTIONS FOR USE

■ ACCESSORIES:

- 1.screw driver and T-hex
- 2.spare board
- 3.socket size: 2*20/ 2*25/ 32/ 40mm
4. pipe cutter

5. measuring tape
6. 1.8m extra cord
7. working gloves
8. stand

■ ASSEMBLY

Fix the welding device to the mold head, then put it into the hob, choose the right mold head for different specification, wrench the whole machine by hexagonal socket, generally smaller one at front bigger one at behind.

■ SETTING UP

Plug in the machine (Please notice that the machine must be plugged into electricity that has ground lead) and the red light will be on. When the red light is on, it means that the machine enters the automatic temperature control mode and you can begin to operate.

The temperature for the welding device has been adjusted, lay people can not adjust, avoid to influence the machine's normal usage and life span.

Cut off the pipe vertically, push the pipe material and pipe piece to the mold head. Press the watch to start operation. Dismantle the pipe material and pipe piece is from the mold head at the same time after reach the heating time, insert the need depth quickly, and the joint place will be symmetrica.

NOTE

If operation environment is below 5°C, the heating time needs to be prolonged 50%.

■ NOTICE

- 1) If the red instruction light long hours do not appear to jump to change, mean the instrument has malfunctions, should stop the work immediately, and cut off the power supply.
- 2) The temperature for the welding device has been adjusted, lay people cannot adjust, avoid to influence the machine's normal usage and life span.

of buy (expect mold head damage, artificial damage), and a free life time service.

■ MAINTENANCE AND SERVICE

We guarantee to keep this machine in good repair three months of date of buy (expect mold head damage, artificial damage), and a free life time service.

Ourter Diametert of Tubular Produc (NM)	Welding depth (NM)	Hating time(s)	Processing time (s)	Cooling time (s)
16	12	4	4	3
20	14	5	4	3
25	16	7	4	3
32	18/1	8	4	4
40	20/5	12	6	4
50	23/5	18	6	5
63	27/4	24	6	6
75	31	30	10	8
90	35/5	40	10	8
110	41/5	50	15	10

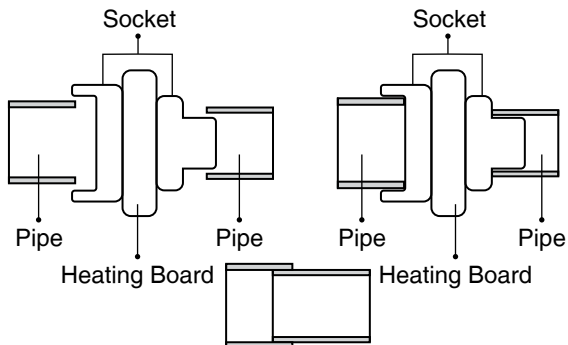

Ronix[®]
Premium Quality